



**morphy richards®**



Register online for your 2 year guarantee. See back of this instruction book for details.  
(UK and Ireland customers only)  
[www.morphyrichards.co.uk](http://www.morphyrichards.co.uk)



## Professional Steel Fryer



Please read and keep these instructions

### **Getting the best from your new fryer...**

#### **Hot Oil**

*Do not attempt to move the fryer while it is still hot - wait two hours after frying for your fryer to cool.*

#### **Easy cleaning**

*Your fryer breaks down into component parts for easy cleaning, but don't immerse the control unit in water*

#### **Storage lid**

*The lid should not be in place during heating up or frying.*

#### **Do not overfill the basket**

*As a guide, do not fill the basket more than half full.*

DF45078 MUK Rev1



**If you have a problem or complaint, please call our dedicated UK based helpline before returning your product to the retailer from where it was purchased.**



UK Helpline: 0844 871 0952  
Replacement Parts: 0844 873 0718  
Ireland Helpline: 1800 409 119



For details of other Morphy Richards products, plus replacement parts and accessories, please see our website:

[www.morphyrichards.com](http://www.morphyrichards.com)





## IMPORTANT SAFETY INSTRUCTIONS

The use of any electrical appliance requires the following common sense safety rules.

Primarily there is danger of injury or death and secondly the danger of damage to the appliance. These are indicated in the text by the following two conventions:

### WARNING: Danger to the person!

IMPORTANT: Damage to the appliance!

In addition we offer the following safety advice.

### Your safety

- **WARNING:** Never attempt to move your fryer until it is completely cool. This can take up to three hours. Use the handles at the side.
- **WARNING: To protect against the risk of electric shock, do not immerse the control unit in water or other liquid.**
- Unplug from the electrical outlet when not in use and before cleaning. Allow to cool before putting on or taking off parts, and before cleaning the appliance.
- Never leave the fryer unattended when connected to the electricity supply.
- Never lean over the fryer when it is in use.
- Be careful not to touch those surfaces of the fryer which become hot when in use.
- This appliance is not intended for use by persons (including children) with reduced physical, sensory or mental capabilities, or lack of experience and knowledge, unless they have been given supervision or instruction

concerning use of the appliance by a person responsible for their safety.

### Product safety

- The control unit and heating element must never be immersed in water.
- When unpacking the fryer, make sure all packing material is removed.
- Never connect the fryer to the electricity supply without oil in the tank.
- Never operate with the oil level below minimum mark or above maximum mark (2.6 litres).
- Do not place the lid on the fryer when in use or heating up. The lid is for storage only.

### Location

- This appliance is intended to be used in household and similar applications such as:

farm houses;

by clients in hotels, motels and other residential type environments;

bed and breakfast type environments.

It is not suitable for use in staff kitchen areas in shops, offices and other working environments.

- Place the appliance on a horizontal, flat and stable surface, away from a heating source and where it cannot be splashed by water.
- Allow adequate air space above and on all sides for air circulation.
- Do not use your fryer under cupboards or shelves.
- Do not use outdoors or near water.

- Do not use your fryer near or below combustible material, such as curtains.

### Other safety considerations

- The use of attachments or tools not recommended or sold by Morphy Richards may cause fire, electric shock or injury.
- Never pour oil out of the fryer with the bowl in position.
- Do not operate any appliance with a damaged cord or plug or after the appliance malfunctions or has been damaged in any manner. Telephone the helpline number (the telephone number can be found on the front cover) for advice on examination and repair.
- Do not use the fryer for anything other than it's intended purpose.
- Always dry food before frying, e.g. chips which are too wet, as they can cause the hot oil to froth excessively.
- This appliance is not intended to be operated by means of an external timer or a separate remote control system.
- This appliance is only to be used with the control unit supplied.

### Children

- Never allow a child to operate this appliance. Teach children to be aware of dangers in the kitchen, warn them of the dangers of reaching up to areas where they cannot see properly or should not be reaching.
- Children do not understand the dangers associated with operating electrical appliances. Never allow children to use this appliance.



- Children should be supervised to ensure that they do not play with the appliance.

### Scalds

- Run cold water over the affected area immediately. Do not stop to remove clothing. Seek medical help immediately.

### Mains cable

- The mains cable should reach from the socket to the base unit without straining the connections.
- Do not let the cable hang over the edge of the table or the counter and keep it away from any hot surface.
- Do not let the cable run across an open space e.g. between a lower socket and table.
- If the supply cable is damaged it must be replaced by the manufacturer, its service agent or similarly qualified persons in order to avoid a hazard.

### ELECTRICAL REQUIREMENTS

Check that the voltage on the rating plate of your appliance corresponds with your house electricity supply which must be A.C. (Alternating Current).

If the socket outlets in your home are not suitable for the plug supplied with this appliance, the plug should be removed and the appropriate one fitted.

**WARNING: The plug removed from the mains cable, if severed must be destroyed, as a plug with a bared flexible cord is hazardous if engaged into a live socket outlet.**

Should the fuse in the 13 amp plug require changing, a 13 amp BS1362 fuse must be fitted.

**WARNING: This appliance must be earthed.**

### Features

The fryer consists of five main components which dismantle easily for cleaning.

- Lid for storage use
- Basket with locking handle (see 'Frying times & temperature chart' for maximum capacity of different foods)
- Control unit with element and cable
- Safety oil filter
- Enamelled tank
- Body
- Variable temperature control
- Power on Indicator (red)
- Reset button
- Cable Storage
- Carrying handles
- Oil level indicator (see note)

### Preparing for the first time

Clean the parts to remove any dust or manufacturing residues.

- Ensure fryer is disconnected from the electricity supply.
- Remove the lid, control unit, basket and tank.
  - Note that the basket handle folds back and locks into position. **B**

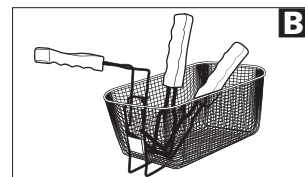
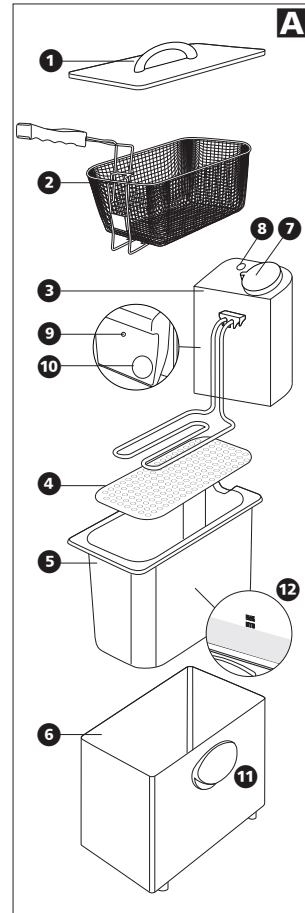

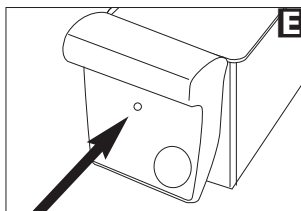
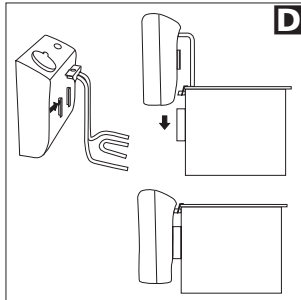
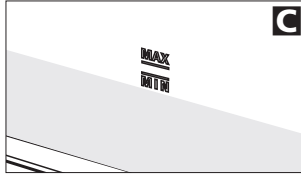

**3** Wash the lid, basket and tank by hand in hot soapy water.

- You can wash the tank in the dishwasher.

**4** Wipe the control unit with a damp cloth and/or paper tissue. **IMPORTANT:** Never immerse the control unit in water.

**5** Dry all parts of your fryer thoroughly and replace the tank, control unit, basket and lid. When replacing the tank, make sure that it is in the correct way round with the max/min lines to the right. **C**

### Assembly

Assemble as shown. **A** Ensure the oil filter is in place and the control unit is correctly fitted to the back ensuring the two ribs of the control unit slide into the two slots. **D** A safety switch prevents the fryer from switching on if fitted incorrectly.

### Filling

Remove the lid and take out the basket.

**IMPORTANT: Do not connect the fryer to the electricity supply if there is no oil in the tank.**

### Filling with oil

Pour the oil into the tank up to the maximum level indicated (approx. 2.6 litres of oil). **C**

### Safety thermostat

The fryer has a safety thermostat that switches fryer off in case of overheating.

This may happen if there is no (or too little) oil in the tank. If the thermostat has switched the fryer off, allow the fryer to cool completely and carefully press the reset button on the back of the fryer. **E**

### Cooking

There are two methods of cooking in your fryer; one general method for most food types and another for home battered products.

Remove the fryer lid before heating up and cooking.

### General cooking method

- Adjust the control dial to the desired temperature.
- Wait 15 minutes for the oil to heat up to the required temperature.
- Lift the basket and put it on the rest. The basket should always be in the raised position when it is to be filled with food.
- Place the food, which should be as dry as possible, into the raised basket. Lower the basket into the tank.

**5** When the food is cooked, place the basket on its raised position for a few seconds to drain.

**6** Remove the basket and put the fried food in a dish with fat absorbing paper (eg. kitchen paper/kitchen roll).

**7** After use, set the temperature knob to the lowest position by turning it towards you, then switch the fryer off. Remove the mains plug from the socket. Allow 2 hours for the oil to cool down.

**8** Wipe any spilt oil from the fryer body.

**9** Press the handle forward to unlock it from its fixed position and lower into the tank.

**10** Replace the storage lid.

### Cooking home battered foods

This method allows for the fact that if wet batter is placed in the basket prior to cooking the food may stick. This method of cooking requires extreme care.

- Adjust the temperature control to the desired temperature.
- Wait 15 minutes for the oil to heat up to the required temperature.

Leave the basket in the down position.

- Coat the raw food in the batter and allow it to drain slightly to get rid of the excess coating.
- Very carefully, slowly lower the coated food into the hot oil, using a suitable implement or tongs. This allows the batter to become solid and prevents it sealing to the mesh of the basket.



**WARNING: Take care as the oil may spit as the food is added.**

- 5 Follow the instructions as given in parts 5 to 10 in general cooking method.

### Getting the best from your fryer

#### Oil

- Always ensure that you use a good quality oil for deep frying. We recommend corn, groundnut, rape seed or vegetable oils. Do not use margarine, butter or olive oil.
- Avoid mixing oil of different qualities.
- Change the oil when it becomes brown or milky in colour.
- If there are water droplets on the base of the tank, the oil should be changed.
- Change the oil in your appliance after frying 15 times.

#### Cooking

- Take into account the food to be cooked before you select your frying temperature.

As a general guide pre-cooked food needs a higher cooking temperature than raw food.

- Your food must always be completely dry in order to avoid overflowing and to prolong the use of the oil.
- All foodstuffs, particularly frozen food and potatoes, contain moisture. When lowered into the hot oil, the water in the food turns to steam and escapes.
- Do not overload the basket as it may cause a drop of the temperature that may leave the food greasy.

- Your fryer will always be ready to use if you store cooled and filtered oil inside, with the lid in place.
- Cook your food thoroughly. Remember that your food may begin to turn golden brown before it is cooked through.
- Select your cooking utensils with care.

Do not use utensils that may melt. Metal utensils become hot and therefore should have insulated handles.

**IMPORTANT:** When using metal utensils take care not to damage the heating element.

- Your fryer has a maximum capacity of 700g of food, depending on food type (see 'Frying times & temperature chart').
- Avoid leaving food to drain for too long in the basket as the food may become soft and lose its crunchiness.

#### Chips

Old potatoes are ideal for making chips. Your chips should be evenly sized so that they cook evenly. They should be rinsed in a colander under a cold tap and dried using a kitchen towel or absorbent paper. For best results fry your chips at 160°C for 4-6 minutes and then place the basket on its rest. Turn the temperature dial to 190°C and when the temperature control light goes out lower the basket again for a further 2-4 minutes. During this time, shake the basket at short intervals to ensure the chips get an even browning.

- For best results with frozen chips, we recommend no more than 600g are being used.

#### Emptying, cleaning

**WARNING: Cleaning should only be carried out when the fryer is switched off and the plug removed from the socket. The fryer should have completely cooled. Allow two hours for the oil to completely cool.**

#### If filled with oil

- 1 Remove the lid, basket and control unit.
- 2 Remove the tank and pour out the oil through fine muslin or absorbent paper placed in a suitable funnel into a container.
- 3 Wash the lid, basket and tank by hand in hot soapy water.
  - You can wash the tank in the dishwasher.
- 4 Clean the control unit with a damp cloth and/or paper tissue.

**IMPORTANT: Never immerse the control unit in water.**

**IMPORTANT: Ensure that the wires connected to the heating element are not damaged while cleaning.**

- 5 Dry all parts of your fryer thoroughly and replace the tank, control unit, basket and lid. When replacing the tank, make sure that it is in the correct way round with the max/min lines to the right. 

You may store your filtered oil in the fryer if you make sure that it is covered by the lid.



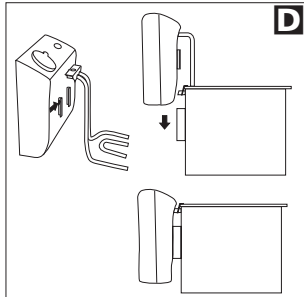

### **Frying times & temperature chart**

These frying times are intended as a guide only and should be adjusted to suit quantity or thickness of food and your own taste.

Fresh chips (700g)  
190°C 10-12 minutes

Frozen chips (600g)  
see packet for temperature or  
190°C 10 minutes

Scampi Frozen in crumbs just  
enough to loosely cover the  
basket area  
170°C 3-5 minutes

Fresh Cod, Haddock in batter  
(150g)  
190°C 5-10 minutes

Frozen Cod, Haddock in  
batter  
170°C 10-15 minutes

Frozen Plaice  
190°C 5-6 minutes

Chicken portions in crumbs\*  
small/medium size  
170°C 15-20 minutes

Large size  
170°C 20-30 minutes

Fresh chicken drumsticks in  
crumbs  
170°C 15 minutes

Beef burgers\*  
100% meat  
170°C 2-3 minutes

\*Chicken and beef burgers  
can taint the oil leaving a  
taste you may not want when  
frying other foods, if so  
change the oil.

## **Trouble shooting**

### **Fryer doesn't switch on**

#### **Not plugged in**

Check the plug is in its  
socket and the switch in the  
'on' position.

#### **Control unit not fitted properly.**

Re-assemble as shown. **D**

#### **Plug itself or the socket faulty.**

Check this by plugging in  
another appliance.

#### **Appliance has been turned on without oil.**

Allow the fryer to cool down  
and press the reset button  
concealed at the back of the  
fryer.

#### **Temperature control dial not at correct setting.**

Choose cooking temperature.

### **Strong smell**

#### **Oil has gone bad.**

Replace the oil.

#### **The correct oil is not being used.**

Use only high quality oil. Do  
not mix oils or fats of  
different types and qualities.

### **Oil overflowing**

#### **Fryer is filled above maximum level.**

Check oil level inside fryer  
body.

#### **Wet food placed in hot oil.**

Dry food.

#### **Stated quantities exceeded.**

Do not fry food above weight  
indicated.

## **Food not browning**

### **Cooking temperature too low.**

Adjust the dial to the correct  
cooking temperature.

### **Basket overloaded.**

Do not fry food above stated  
quantities and weight.

### **Oil not hot enough.**

Faulty thermostat. Telephone  
Morphy Richards consumer  
service using the helpline  
number.

### **Chips sticking together**

Food not washed before  
being placed into hot oil.  
Wash potatoes thoroughly  
and dry carefully.

## **Helpline**

If you have any difficulty with  
your appliance, do not  
hesitate to call us.

We are more likely to be able  
to help than the store from  
where you bought it. Please  
have the following  
information ready to enable  
our staff to deal with your  
query quickly.

- Name of the product.
- Model number as shown on  
the underside of the  
appliance.
- Serial number as shown on  
underside of the appliance.

**UK Helpline 0844 871 0952**

**Replacement Parts 0844 873 0718**

**Ireland Helpline 1800 409 119**

## **Website**

You may also contact us  
through our website, or visit  
the site to browse and  
purchase appliances, spare  
parts and accessories from  
the extensive Morphy  
Richards range.

**[www.morphyrichards.com](http://www.morphyrichards.com)**



This page is intentionally left blank.





## REGISTERING YOUR TWO YEAR GUARANTEE

Your standard one year guarantee is extended for an additional 12 months when you register the product within 28 days of purchase with Morphy Richards. If you do not register the product with Morphy Richards within 28 days, your product is guaranteed for 1 year. To validate your 2 year guarantee register with us online at [www.morphyrichards.co.uk](http://www.morphyrichards.co.uk)

N.B. Each qualifying product needs to be registered with Morphy Richards individually.

**Please note that the 2 year guarantee is only available in the UK and Ireland.** Please refer to the one year guarantee for more information.

## YOUR ONE YEAR GUARANTEE

It is important to retain the retailer's receipt as proof of purchase. Staple your receipt to this back cover for future reference.

Please quote the following information if the product develops a fault. These numbers can be found on the base of the product.

### Model no.

### Serial no.

All Morphy Richards products are individually tested before leaving the factory. In the unlikely event of any appliance proving to be faulty within 28 days of purchase, it should be returned to the place of purchase for it to be replaced.

Morphy Richards products are intended for household use only. See usage limitations within the location safety instructions.

Morphy Richards has a policy of continuous improvement in product quality and design. The company, therefore reserves the right to change the specification of its models at any time.

If the fault develops after 28 days and within 12 months of original purchase, you should contact the Helpline number quoting Model number and Serial number on the product, or write to Morphy Richards at the address shown.

You may be asked to return a copy of proof of purchase.

Subject to the exclusions set out below (see Exclusions), the faulty appliance will then be repaired or replaced and dispatched usually within 7 working days of receipt.

If, for any reason, this item is replaced during the 1 year guarantee period, the guarantee on the new item will be calculated from original purchase date. Therefore it is vital to retain your original till receipt or invoice to indicate the date of initial purchase.

To qualify for the 1 year guarantee, the appliance must have been used according to the instructions supplied. For example, crumb trays should have been emptied regularly.

## EXCLUSIONS

Morphy Richards shall not be liable to replace or repair the goods under the terms of the guarantee where:

- 1 The fault has been caused or is attributable to accidental use, misuse, negligent use or used contrary to the manufacturer's recommendations or where the fault has been caused by power surges or damage caused in transit.
- 2 The appliance has been used on a voltage supply other than that stamped on the products.

3 Repairs have been attempted by persons other than our service staff (or authorised dealer).

4 The appliance has been used for hire purposes or non domestic use.

5 The appliance is second hand.

6 Morphy Richards are not liable to carry out any type of servicing work, under the guarantee.

7 Plastic filters for all Morphy Richards kettles and coffee makers are not covered by the guarantee.

8 Batteries and damage from leakage are not covered by the guarantee.

- This guarantee does not confer any rights other than those expressly set out above and does not cover any claims for consequential loss or damage. This guarantee is offered as an additional benefit and does not affect your statutory rights as a consumer.

- This guarantee is valid in the UK and Ireland only.



For electrical products sold within the European Community. At the end of the electrical products useful life, it should not be disposed of with household waste. Please recycle where facilities exist. Check with your Local Authority or retailer for recycling advice in your country.

**morphy richards®**

**The After Sales Division  
Morphy Richards Ltd**  
Mexborough, South Yorkshire,  
England, S64 8AJ

Helplines (office hours)  
UK 0844 871 0952  
Spare Parts 0844 873 0718  
Republic of Ireland 1800 409 119

DF45078 MUK Rev1 05/10

For details of other Morphy Richards products, plus replacement parts and accessories, please see our website:

[www.morphyrichards.com](http://www.morphyrichards.com)

